





Important safety instructions:

- Please read carefully all instructions before assembly.
- For your safety and ease, assembly by two or more adults is recommended.
- Keep instructions for future use.



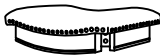

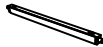
Pre-assembly:

- Do not discard any content until assembly is complete to avoid accidentally discarding small parts or hardware.
- Take out all parts and hardware from box.

Parts List

Item	Description	QTY
P1	Seat 	1
P2	Legs 	4
P3	Front Stretchers 	2
P4	Side Stretchers 	2

Hardware List

Item	Description	QTY
H1	Bolt 1/4" x 2-3/8" 	8
H2	Spring Washer 1/4" 	8
H3	Flat Washer 1/4" 	8
H4	Screw M4 x 1-1/2" 	8
H5	Allen Key M4 	1

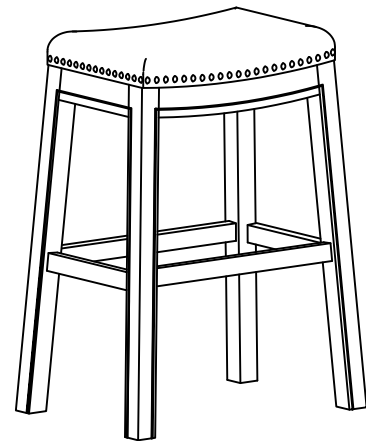

DISCLAIMER:

WHEN PROPERLY ASSEMBLED, THIS ITEM IS SAFE FOR INTENDED USE. SELLER IS NOT LIABLE FOR ANY DAMAGES RESULTING FROM ITEM BEING IMPROPERLY ASSEMBLED AFTER PURCHASE.

Assembly Procedure :

Step 1. Attach legs (P2) to Seat (P1) by using 2 Bolts (H1) , 2 Spring Washers (H2) & 2 Flat Washers (H3) .

Do not tighten bolts on this step.

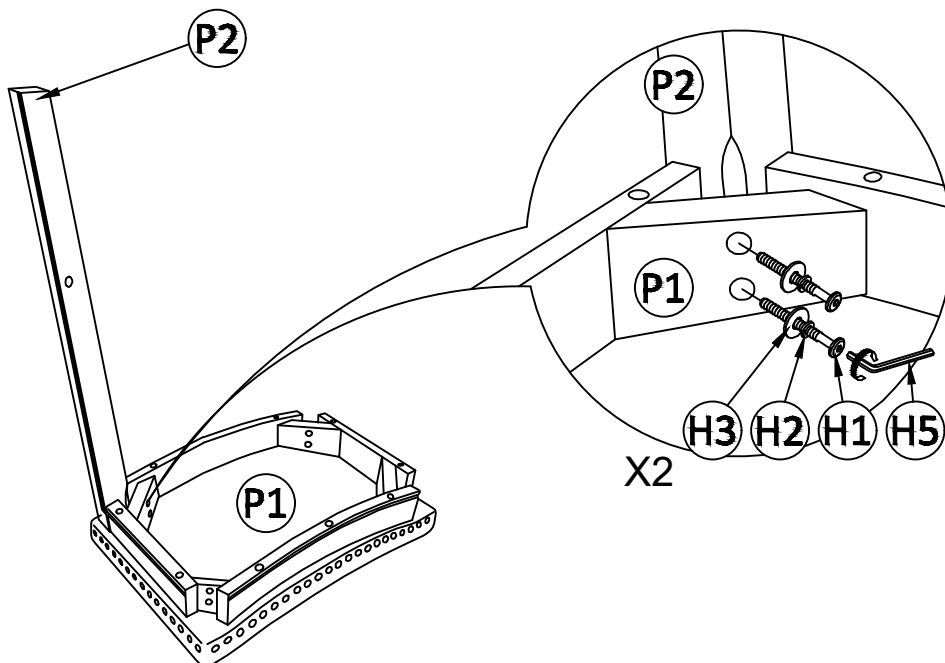

Step 2. Insert one of side stretcher (P4) into hole on leg (P2) . Loosely attach other leg (P2) to seat (P1) and side stretcher (P4) . Do not tighten bolts on this step.

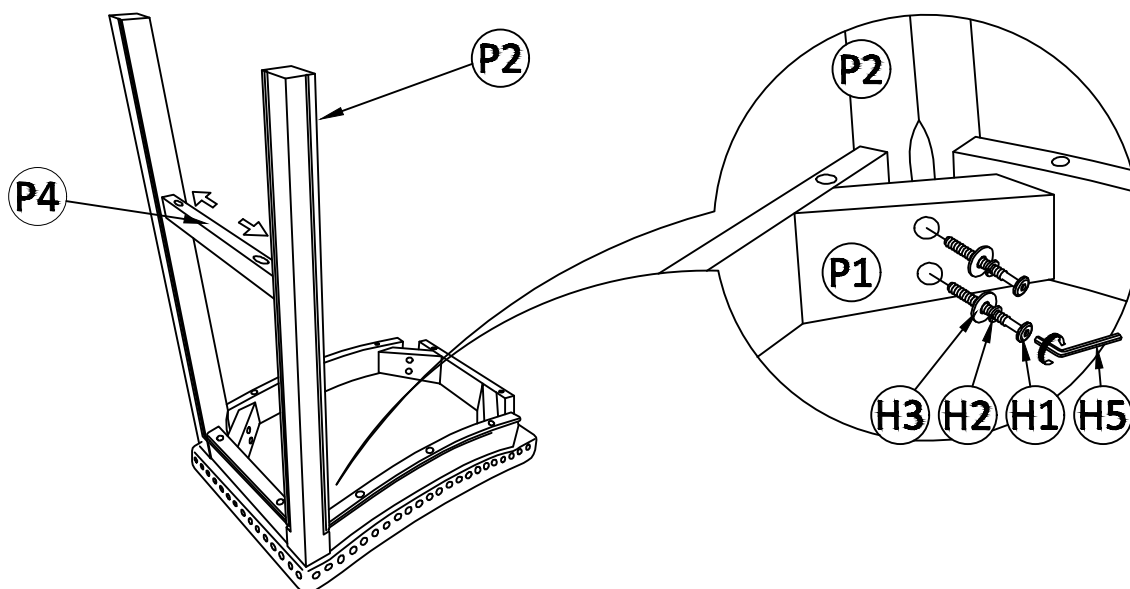

Step 3. Insert one of front stretcher (P3) into hole on leg (P2) . Loosely attach other leg (P2) to seat (P1) and front stretcher (P3) . Do not tighten bolts on this step.

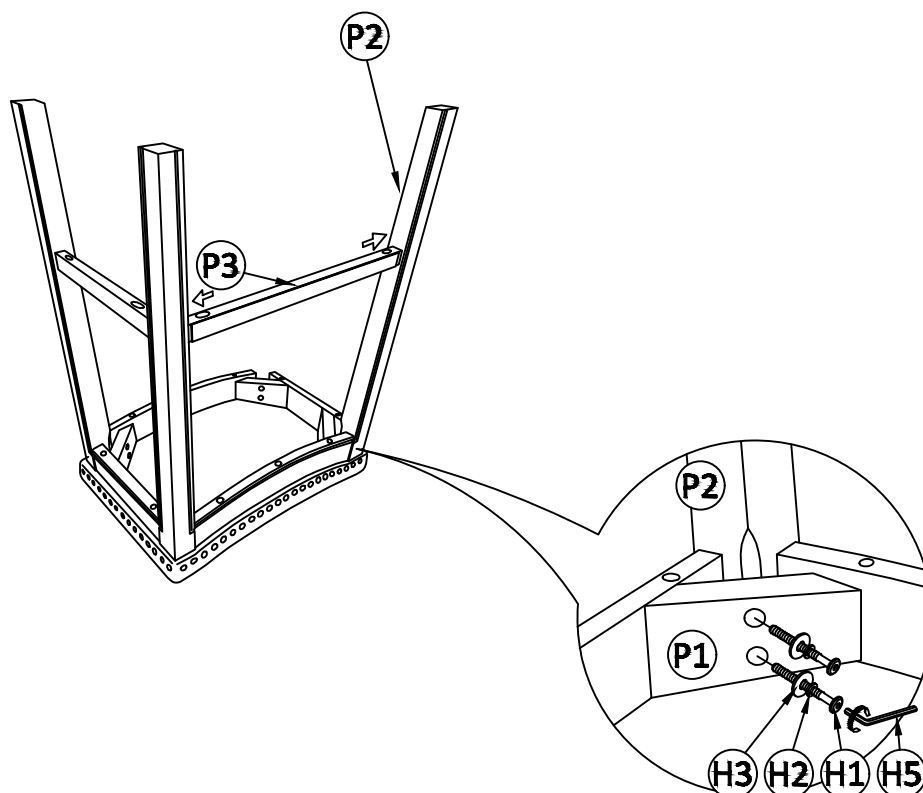

Step 4. Insert one of side stretcher (P4) and one front stretcher (P3) into hole on leg (P2) . Loosely attach other leg (P2) to seat (P1) , side stretcher (P4) and front stretcher (P3) . Do not tighten bolts on this step.

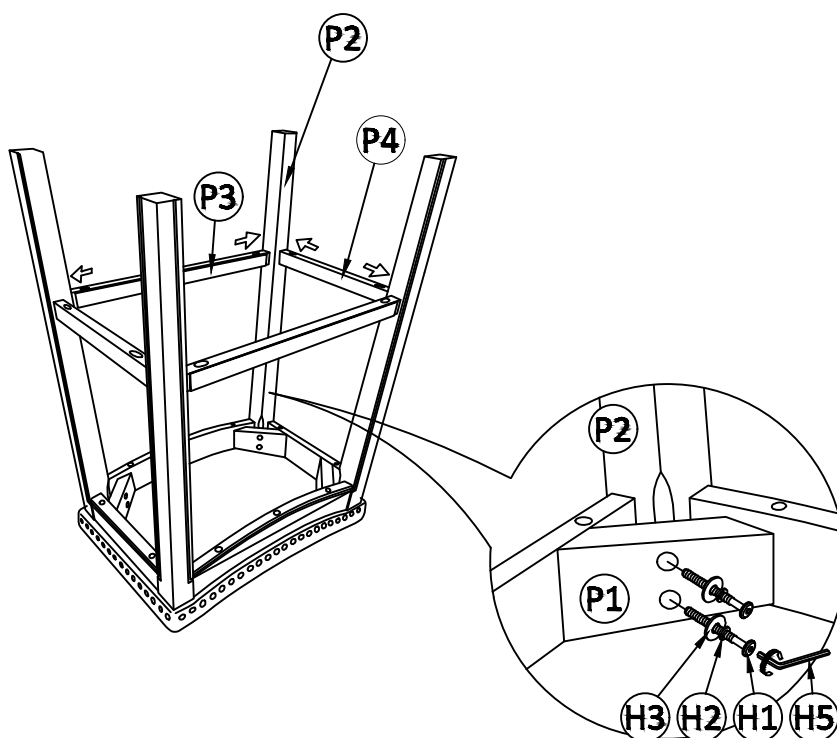

Step 5. Use Screw (H4) to fasten front stretcher (P3) and side stretchers (P4) to legs. Use screw driver to fix the screws. Tighten all bolts with allen key.

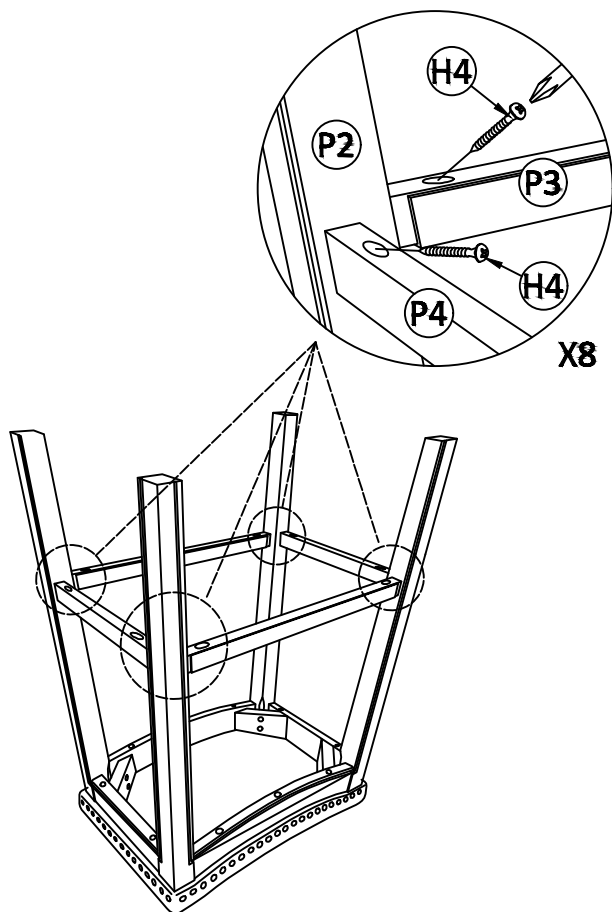

Leg Level Guidance

Before tightening all bolts , turn over the chair so it sits on legs , and adjust the legs to level the chair. Then tighten all the bolts.

CAUTION : When tightening the bolts, tighten sequentially.

DO NOT tighten any screw fully and then proceed to the next one. This could cause the frame to warp.

WARNING !!

IF CHAIR NOT STABLE, IT COULD LEAD TO DAMAGING THE PRODUCT.

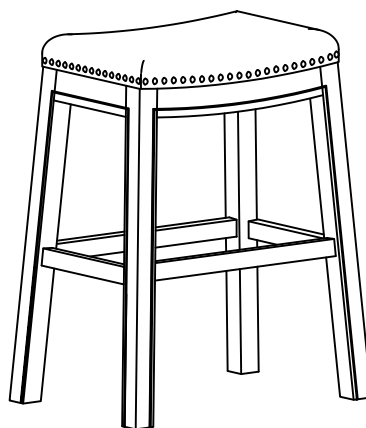

ADDITIONAL NOTE ABOUT SAFETY :

BOLTS MAY LOOSEN DURING NORMAL EVERYDAY USE.

THEY SHOULD BE INSPECTED AT LEAST EVERY 3 MONTHS AND RE-TIGHTENED AS NEEDED TO PREVENT DAMAGE OR INJURY AND ENSURE STABILITY.